



# ECU-R

## Energy Communication Unit

- Collection and transmission of inverter data
- Real time monitoring of each inverter
- Stable wireless encrypted ZigBee communication with microinverters, built-in Wi-Fi
- Small size, flexible installation
- Working with CHINT meter to provide Export Power Control and metering function

## PRODUCT FEATURES

The APsystems Energy Communication Unit (ECU-R) is the information gateway for our microinverters. The ECU-R collects module performance data from each individual microinverter and transfers the information to an Internet database in real time. Through the APsystems Energy Monitoring and Analysis (EMA) software, the ECU-R gives you precise analysis of each microinverter and PV module in your solar installation powered by APsystems. The user-friendly interface gives you access to your solar array performance in seconds from our web based portal or from our APP.

When working with CHINT meter, ECU-R can offer advanced functions, e.g. Export Power Control, Consumption Monitoring and RGM (Revenue Grade Meter).

## DIMENSIONS

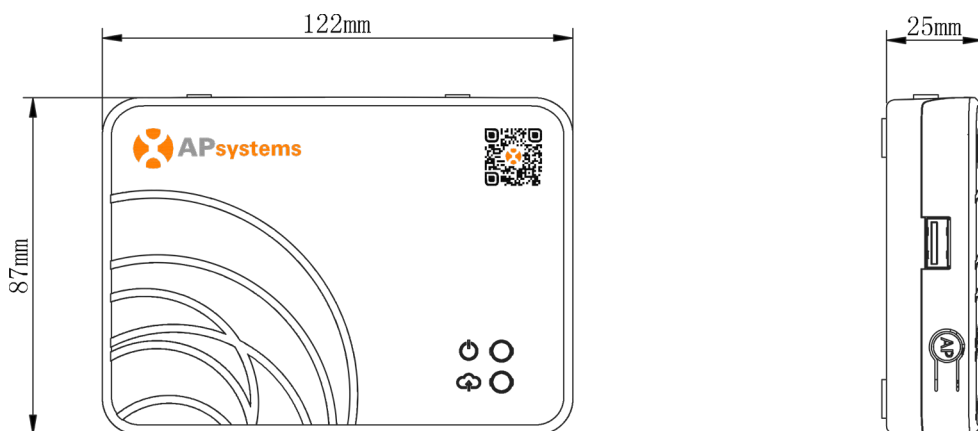

# ECU-R Datasheet

## Model

ECU-R

## Communication to Microinverter

Communication	ZigBee 2.4 GHz
Maximum Communicating Inverter*	100

## Communication to EMA

Ethernet	10/100M Auto-sensing, Auto-negotiation
Wireless	Wi-Fi 802.11b/g/n
Wireless Security	WEP, WPA2-PSK
USB Interface	5Vdc - 0.5A Output

## Communication to Meter

Communication	RS485 to CHINT meter
---------------	----------------------

## Power Data

Power Supply	5V, 2A
Power Consumption	1.7 W

## Product Specifications

Frequency Range	2412MHZ-2472MHZ (WIFI), 2405mhz-2480mhz (ZigBee)
RF Output Power (EIRP)	16.56 dbm (WIFI), 9.50 dbm (ZigBee)
Type of Antenna	External antenna,SMA type connector
Modulation	DSSS, OFDM
Mode of Operation(Simplex/Duplex)	Duplex

## Mechanical Data

Dimensions (W×H×D)	122 mm x 87 mm x 25 mm (4.8" x 3.4" x 0.98")
Weight	150g (0.33lbs)
Operating Ambient Temperature Range	-20°C to +65°C (-4°F to +149°F)
Cooling	Natural Convection; No Fans
Enclosure Environmental Rating	Indoor - NEMA 1 (IP20)
Warranty	3 Years Standard

## Features

Function (Optional)	Working with CHINT Meter to provide Export Power Control, Consumption monitoring and RGM function
---------------------	---

## Compliance

Compliance	IEC 60950-1, EN60950-1, IEC 60529, EN 60529, ANSI/UL 60950-1, CAN/CSA C22.2 No.60950-1, UL50E, FCC part 15, EN61000-6-1, EN61000-6-3, ICES-003, AS NZS 60950-1, GB/T17799
------------	---

\*Maximum number of microinverters per ECU may vary depending on the PV array size and layout, maximum distance between ECU and microinverters in the array, obstacles (thick concrete wall, metallic roof top).



Please scan this QR code to download our APPs or check the link:  
<https://apsystems.com/qr-code/>



© All Rights Reserved  
Specifications subject to change without notice - please ensure you are using the most recent update found at [www.APsystems.com](http://www.APsystems.com)